



Standard Test Method for Single-Point Determination of Specific Surface Area of Catalysts and Catalyst Carriers Using Nitrogen Adsorption by Continuous Flow Method¹

This standard is issued under the fixed designation D 4567; the number immediately following the designation indicates the year of original adoption or, in the case of revision, the year of last revision. A number in parentheses indicates the year of last reapproval. A superscript epsilon (ϵ) indicates an editorial change since the last revision or reapproval.

1. Scope

1.1 This test method covers the single-point determination of the surface area of catalysts and catalyst carriers that exhibit Type II or Type IV nitrogen adsorption isotherms using a nitrogen-helium flowing gas mixture. This test method is applicable for the determination of total surface areas from 0.1 to 300 m², where rapid surface area determinations are desired.

1.2 Because the single-point method uses an approximation of the BET equation, the multipoint BET method (Test Method D 3663) is preferred to the single-point method.

NOTE 1—This is particularly true when testing microporous materials.

1.3 The values stated in SI units are to be regarded as standard. No other units of measurement are included in this standard.

1.4 *This standard does not purport to address all of the safety concerns, if any, associated with its use. It is the responsibility of whoever uses this standard to consult and establish appropriate safety and health practices and determine the applicability of regulatory limitations prior to use.*

2. Referenced Documents

2.1 *ASTM Standards:*²

D 3663 Test Method for Surface Area of Catalysts and Catalyst Carriers

D 3766 Terminology Relating to Catalysts and Catalysis

E 177 Practice for Use of the Terms Precision and Bias in ASTM Test Methods

E 456 Terminology Relating to Quality and Statistics

E 691 Practice for Conducting an Interlaboratory Study to Determine the Precision of a Test Method

3. Terminology

3.1 *Definitions*—See Terminology D 3766.

3.2 *Symbols:*

A_{cs} = cross-sectional area of nitrogen, 16.2×10^{-20} m².

C_I = integrator counts.

$C_{I,Ta}$ = integrator counts corrected for ambient temperature.

$C_{I,Pa}$ = integrator counts corrected for ambient pressure.

N = Avogadro's number, 6.02×10^{23} , molecules/mole.

P = partial pressure of nitrogen, torr.

P_a = ambient pressure, torr.

P_o = saturated equilibrium vapor pressure of liquid nitrogen, torr.

R = gas constant, 82.1 cm³ atm/K mole.

T_a = ambient temperature, K.

V = volume of nitrogen adsorbed at ambient temperature and pressure, cm³.

W_1 = tare of sample cell, g.

W_2 = sample mass + tare of sample cell after analysis, g.

W_s = mass of sample, g.

4. Summary of Test Method

4.1 The sample is degassed by heating in a flow of inert gas to remove adsorbed vapors from the surface. The sample is then immersed in a liquid nitrogen bath causing adsorption of nitrogen from a flowing mixture of a fixed concentration of nitrogen in helium. When adsorption is complete, the sample is allowed to warm to room temperature causing desorption, which results in an increase in the nitrogen concentration in the

¹ This test method is under the jurisdiction of Committee D32 on Catalysts and is the direct responsibility of Subcommittee D32.01 on Physical-Chemical Properties.

Current edition approved April 1, 2008. Published April 2008. Originally approved in 1986. Last previous edition approved in 2003 as D 4567-03.

² For referenced ASTM standards, visit the ASTM website, www.astm.org, or contact ASTM Customer Service at service@astm.org. For *Annual Book of ASTM Standards* volume information, refer to the standard's Document Summary page on the ASTM website.

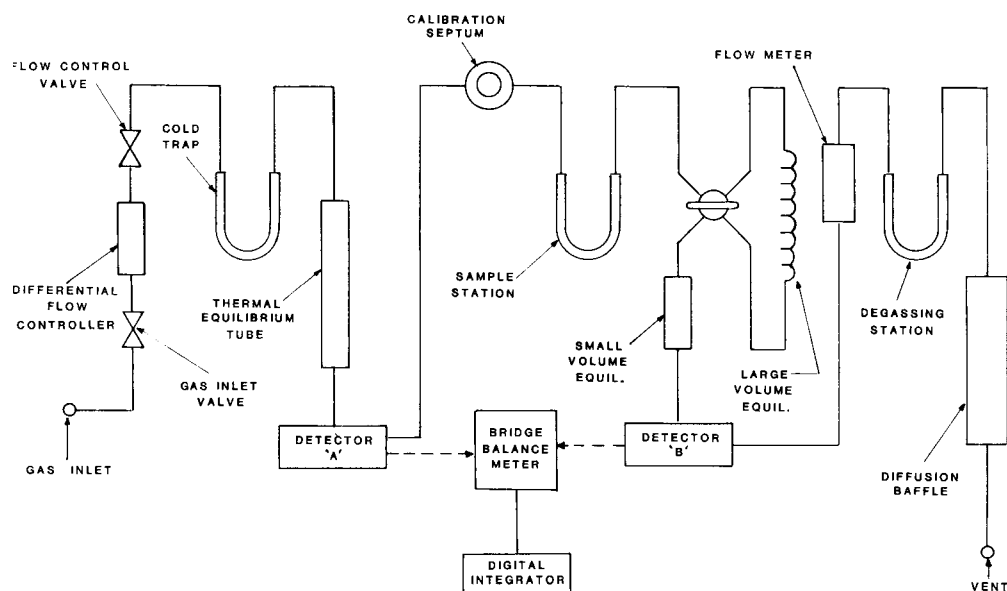

FIG. 1 Apparatus

flowing mixture. The quantity of nitrogen gas desorbed is determined by sensing the change in thermal conductivity.

4.2 Calculation of the surface area is based on a modified form of the BET equation.

5. Significance and Use

5.1 This test method is useful for determining the specific surface area of catalysts and catalyst carriers for material specifications, manufacturing control, and research and development in the evaluation of catalysts.

6. Apparatus

6.1 A schematic diagram of the apparatus is shown in Fig. 1. The apparatus may be constructed of glass or metal tubing. It has the following features:

6.1.1 *Differential Flow Controller* from the gas inlet valve to a flow control valve to eliminate fluctuations in the gas flow.

6.1.2 *Two Thermal Conductivity Detectors*—A reference detector (A) to sense the nitrogen-helium gas mixture and a second detector (B) to sense changes in the gas mixture after flowing through the sample cell. The two detectors are initially balanced to allow the detection of changes in the nitrogen concentration.

6.1.3 *Flow-Through Sample Cells*, of various volumes and shapes depending on the application.

6.1.4 *Two Equilibration Tubes* selected by a selector valve, between the sample cell and detector (B). The small volume tube has a volume of approximately 20 cm³ and the large volume tube has a 100 cm³ capacity to allow for temperature and pressure equilibration of a wide range of volumes of gases.

6.1.5 *Flow Meter*, to monitor the flow rate of the nitrogen-helium mixture maintained at approximately 20 cm³/min.

6.1.6 *Diffusion Baffle*, to prevent air from diffusing back into the system during cooling of the sample.

6.1.7 *Bridge Balance Meter*, to display balance or imbalance between detectors A and B.

6.1.8 *Digital Integrator*, to measure the imbalance between detectors A and B and display the surface area of the sample.

6.1.9 *Septum or Fixed Loop*, for injection of calibration gas.

6.1.10 *Degassing Station*, for removal of adsorbed vapors from the sample.

6.1.11 *Cold Trap*, for removal of impurities in the gas mixture.

6.1.12 *Thermal Equilibration Tube*, to allow the flowing gas mixture to reach temperature and pressure equilibration before reaching detector (A).

6.2 *Heating Mantle*.

6.3 *Dewar Flasks*.

6.4 *Laboratory Balance* with 0.1 mg (10⁻⁷ kg) sensitivity.

6.5 *Gas-Tight Syringe or Gas Sampling Loop*, 1.00 cm³.

7. Reagents

7.1 *Liquid Nitrogen*, of such purity that the saturated equilibrium vapor pressure is not more than 20 torr above ambient pressure.

7.2 *Cylinder*, with pressure regulator, of high purity 30 mole % nitrogen in helium equivalent to a relative pressure of approximately 0.3, where the nitrogen concentration is known to within 0.1 mole %. Concentrations lower than 30 mole % should be used for materials containing micropores, for example, zeolites.

8. Calibration of the Apparatus

8.1 If the gas mixture contains impurities, place a Dewar flask containing liquid nitrogen around the cold trap.

8.2 Using a gas-tight syringe inject 1.00 cm³ (or some other known volume) of air or nitrogen into the calibration septum. The digital integrator should display 2.84 ± 0.03 counts (see 11.3) for a 1.00-cm³ injection (or a proportional number of counts for a different volume). If the counts are greater than 2.84, increase the gas flow through the flow control valve. If the counts are less than 2.84, decrease the gas flow and retest.